

# Softlite PC Corrugated Sheet

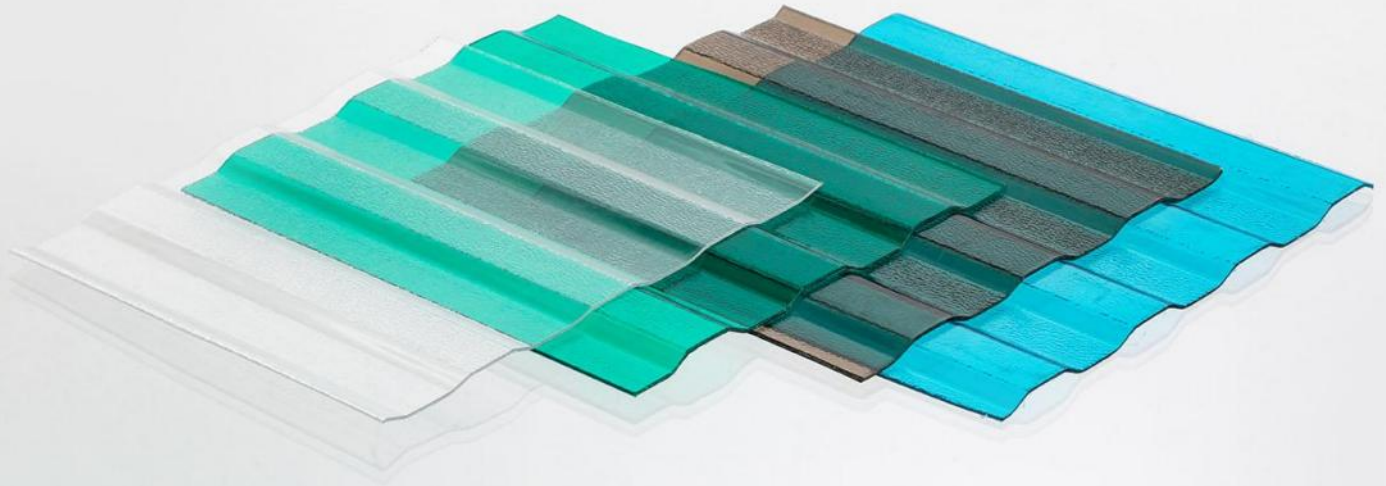



Softlite uses polycarbonate (Covestro/SABIC) raw materials. Double sided anti UV coating can improve outdoor service life. Advantages of Softlite: The roll material is easy to transport, the length can be customized, the installation is simple, the construction is fast, and the deflection is strong (1.5mm thickness Softlite  $\approx$  3mm thickness PC solid sheet).

The surface of Softlite is frosted embossed, with soft and bright light. Softlite is used as a panel material for carport and canopy roofs.

**Product design concept: Easy to transport, Easy to install.**

## SIZE:

Thickness: 1.0mm, 1.2mm, 1.5mm, 1.8mm, 2.0mm

Width: 1.26 m

Length: 30-50M/Roll(or custom)

模具号 Mould	图 Profile	搭接宽 Effective width (mm)	最小弯曲半径 Min curving radius (M)
洁光瓦 Softlite		1160	2

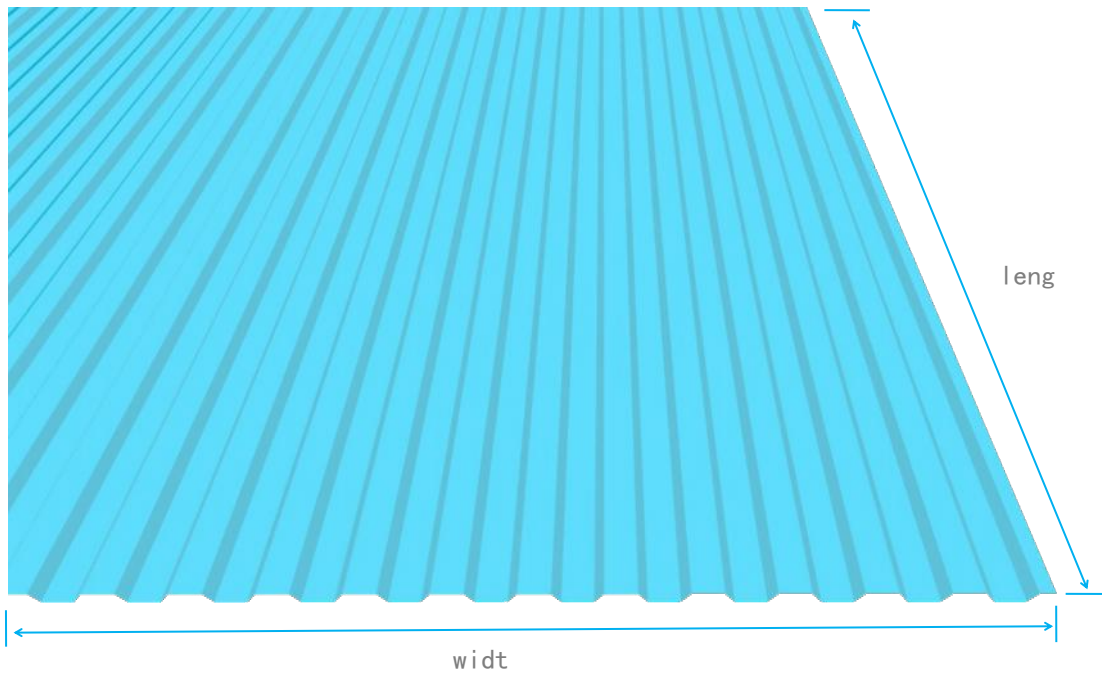

Specifications	1.0mm(1.26*50M)	<b>1.2mm(1.26*50M)</b>	1.5mm(1.26*30M)	1.8mm(1.26*30M)	2.0mm(1.26*30M)
Weight (KG/roll)	78	93.6	70.2	84.24	93.6
Volume (m³)	0.36	0.25	0.36	0.42	0.48
Diameter per volume (M)	0.6	0.5	0.6	0.65	0.7

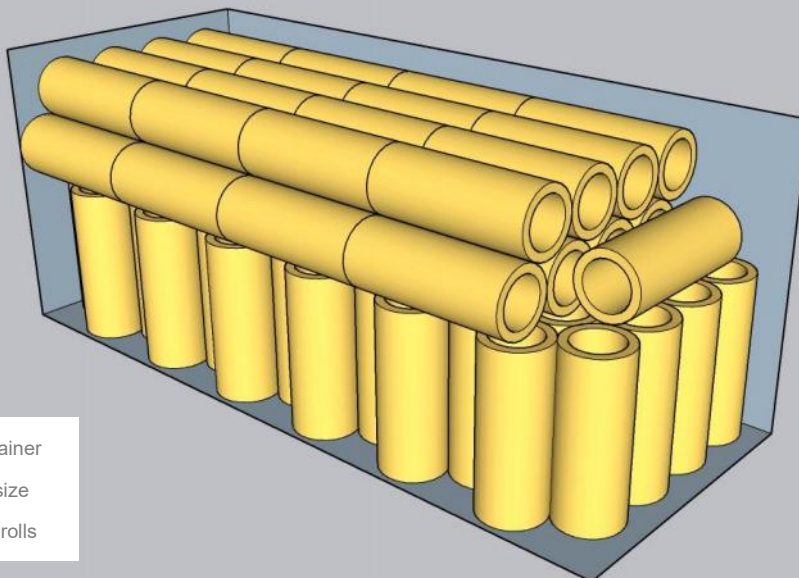

Simulation: 20GP container  
1.2mm (1.26 \* 50M) size  
It can be loaded in 85 rolls



-Product Details-



-Product Details-

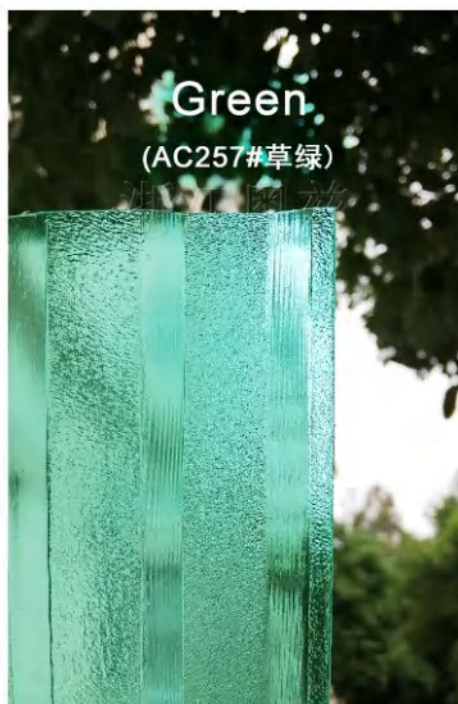
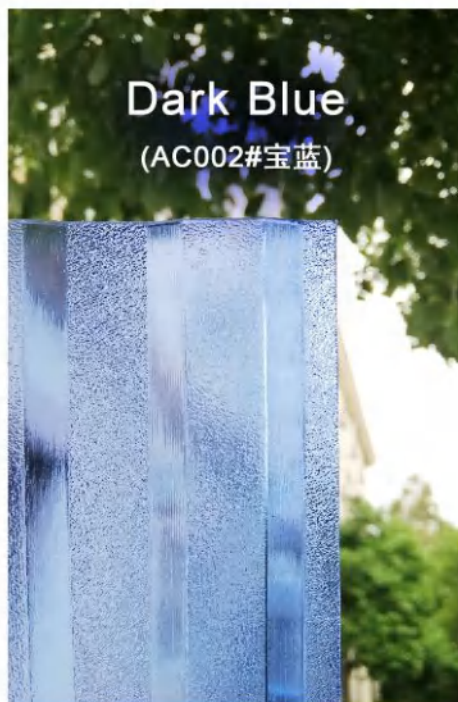

## Outdoor Photos

-Colour



Polycarbonate raw material



Polycarbonate particles

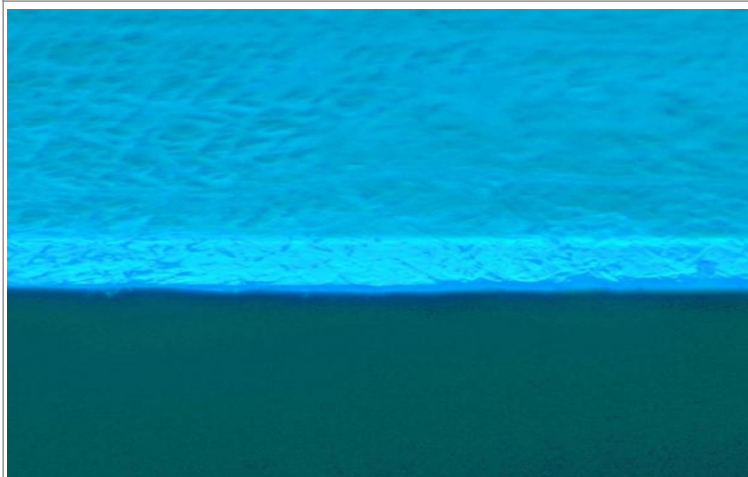

Double-sided UV anti-aging coating process



Production facility



Pack



Transportation mode 1



Transportation mode 2



Factory

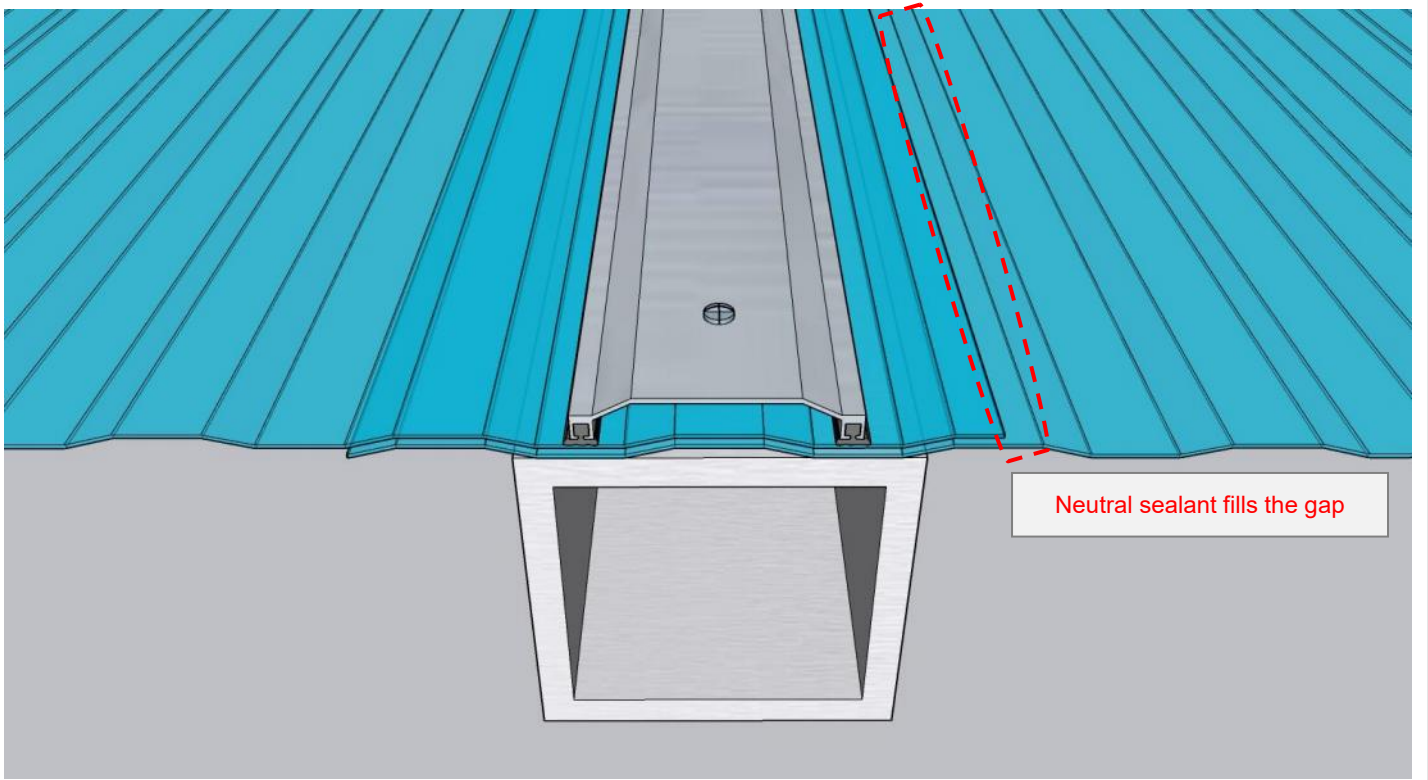

Install 1: Aluminum profile is pressed against the gap

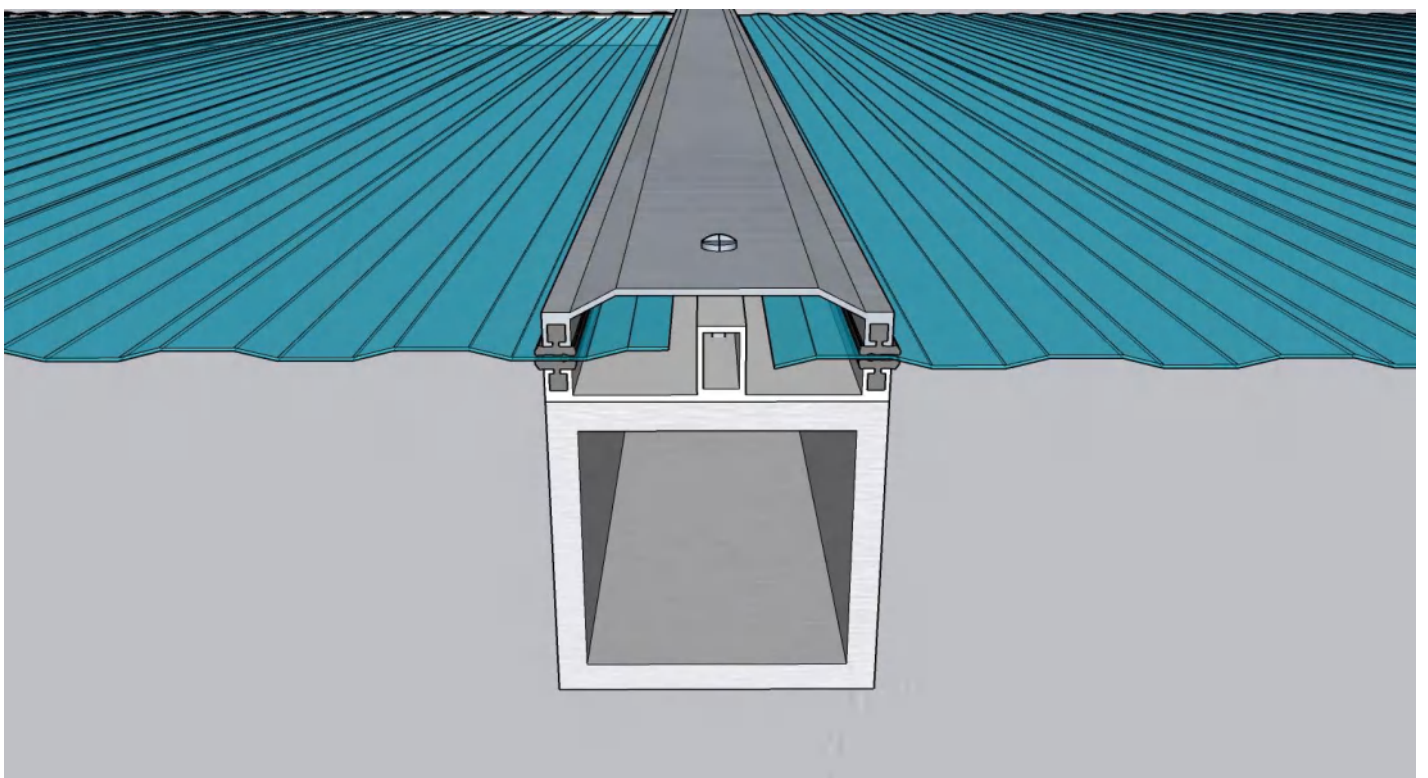

Install 2: Aluminum profile splicing gap

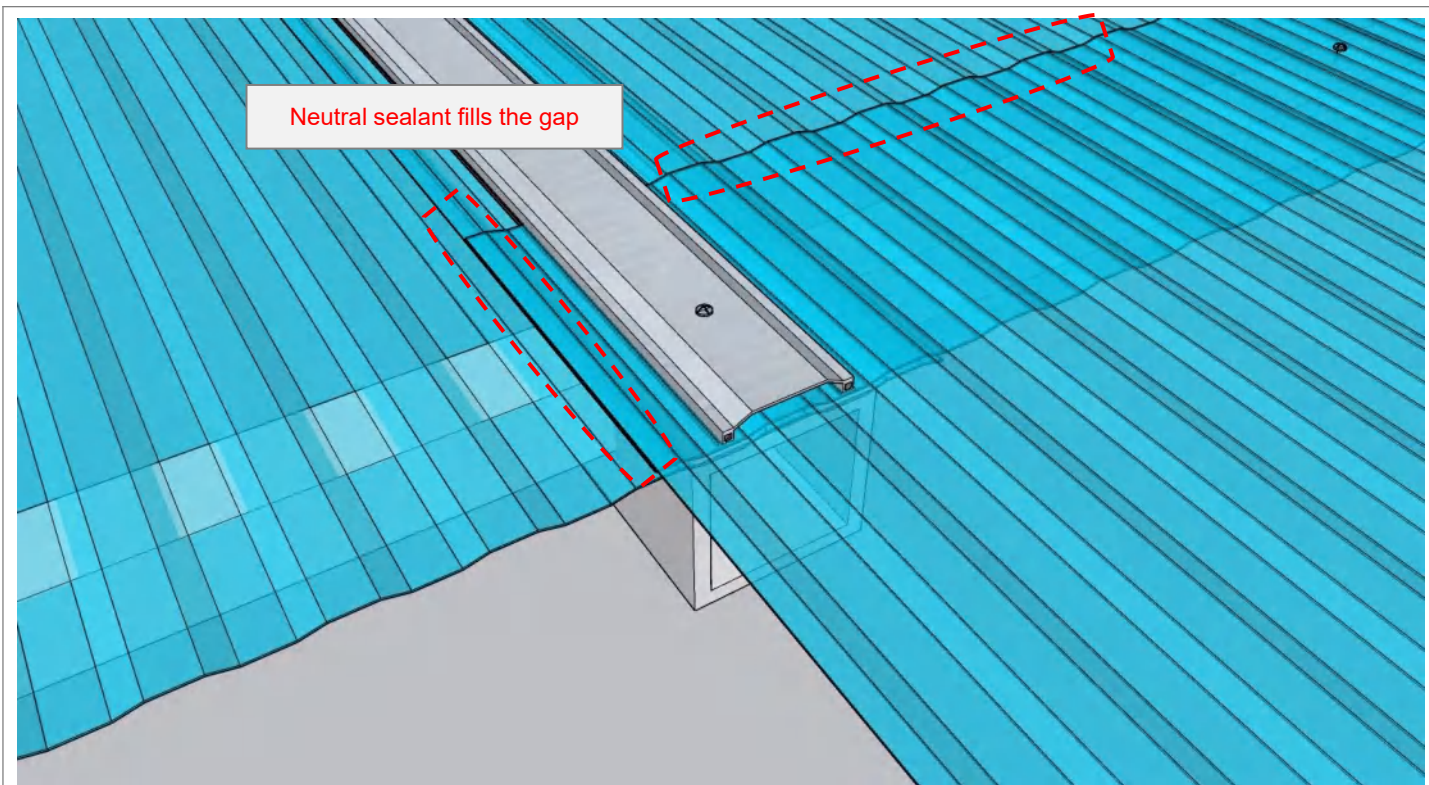

Schematic diagram of nodes 1

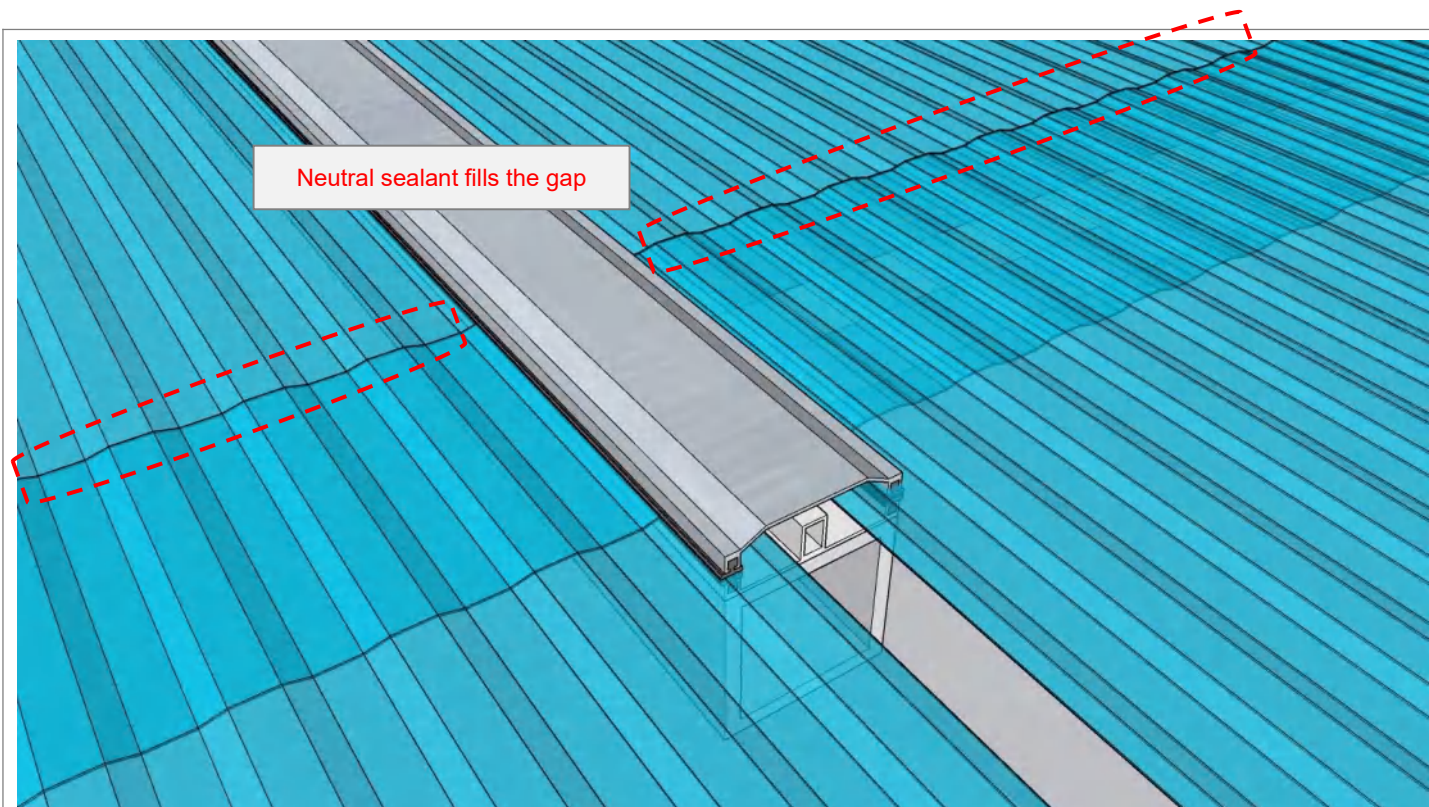

Schematic diagram of nodes 2

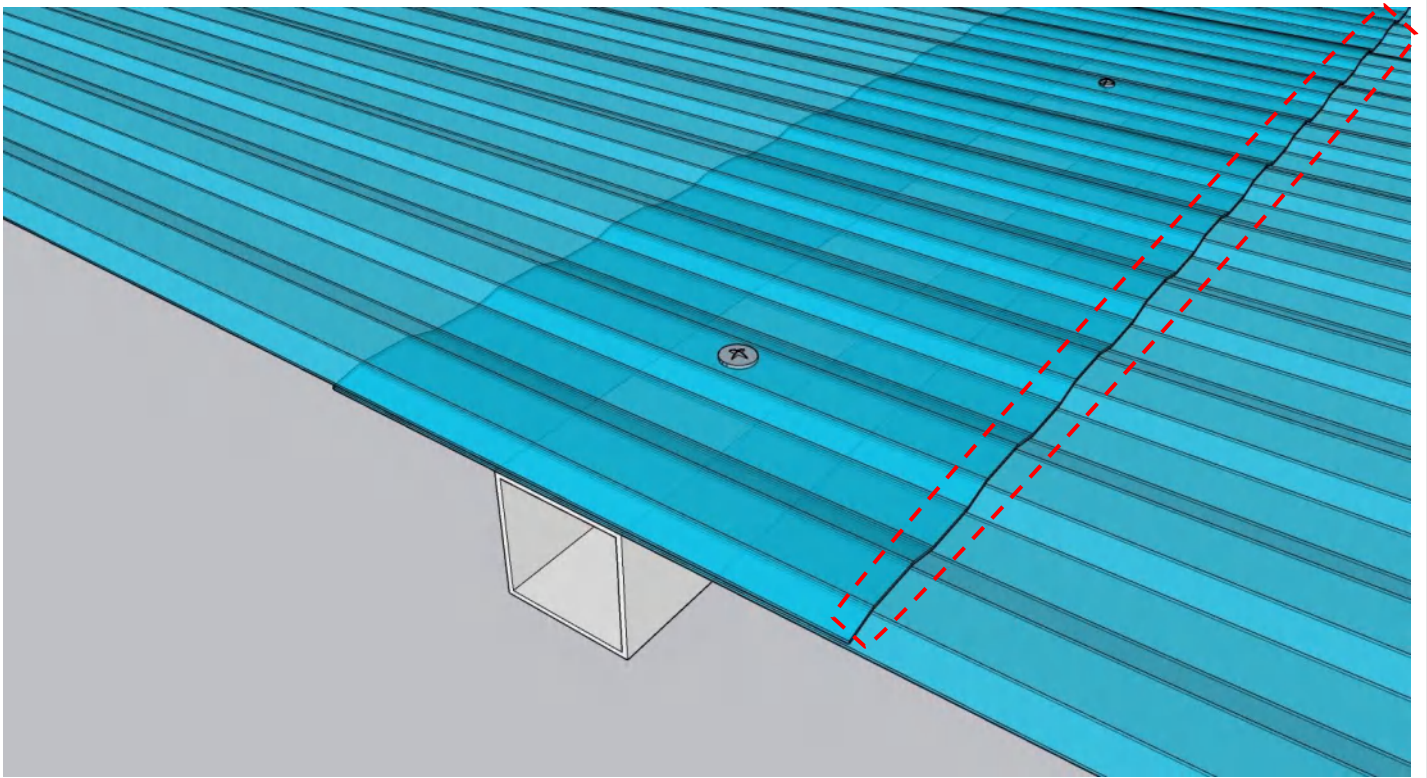

When the upper and lower lap, the handover length is 20cm, and the gap should be filled with neutral silicone sealant.

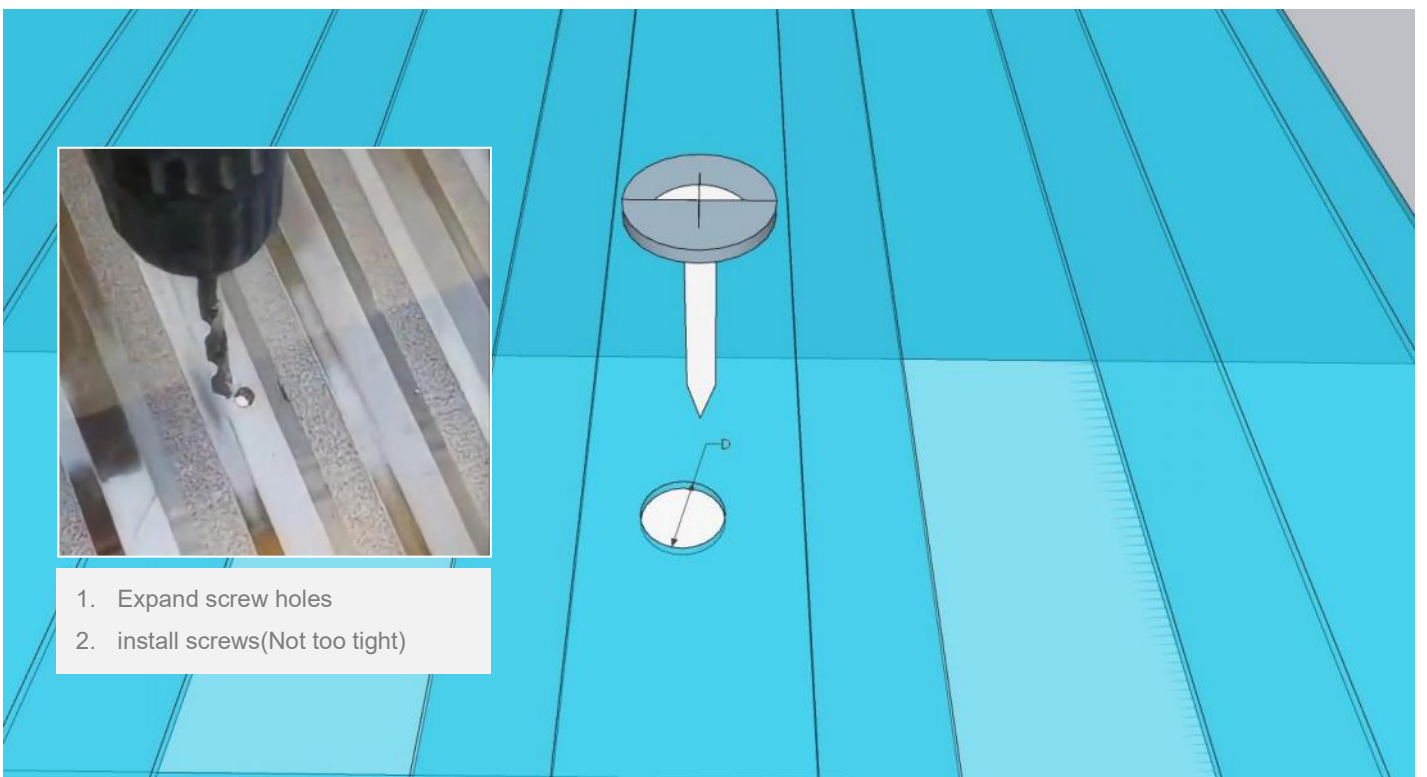

A waterproof gasket is required for installation. The screw hole location requires a drill bit to enlarge the hole. The diameter of the enlarged hole should be 4mm larger than the diameter of the screw to avoid tensile cracks caused by thermal expansion and cold contraction.





E-Mail: [polycarbonatesheet@qq.com](mailto:polycarbonatesheet@qq.com)